

REV	ECN.NO:	BY	DATE
A0	NEW DWG	ZHULIZHI	11.01.14

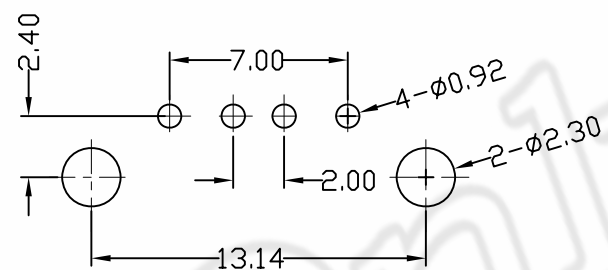
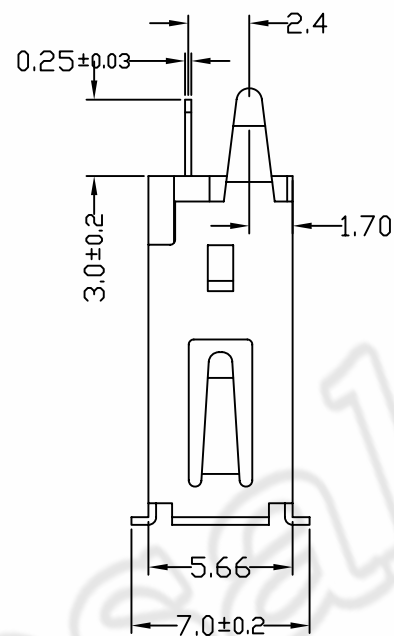
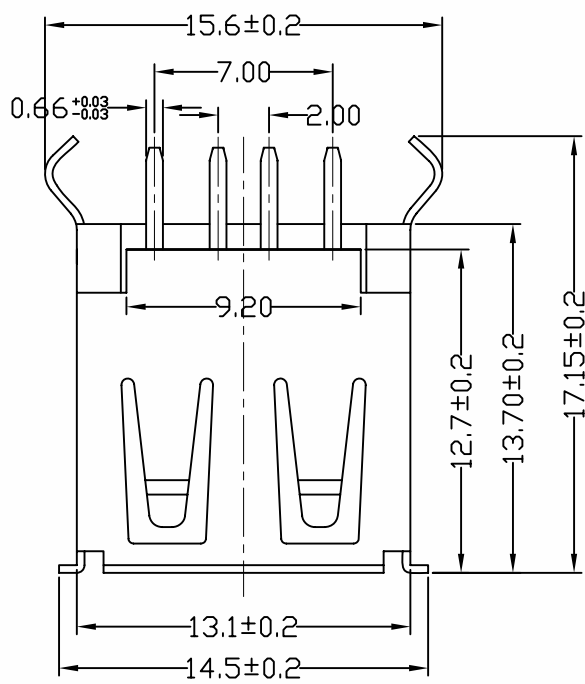

P.C.B LAYOUT
BOTTOM VIEW

NOTES:

1. MATERIAL:
 - 1.1 HOUSING: PBT, UL94 V-0; COLOR: BLACK
 - 1.2 CONTACT: C5191
 - 1.3 SHELL: C2680
2. FINISH:
 - 2.1 CONTACT:
 - GOLD PLATING(SEE TABLE) ON CONTACT AREA.
 - 2.54um [100u"] MIN. MATTE-TIN PALTING ON SOLDER TAIL AREA.
 - 1.27um [50u"] MIN. NICKEL UNDERPLATING OVERALL.
 - 2.2 SHELL:
 - 1.27um [50u"] MIN. NICKEL PLATING OVERALL.
3. OTHER GENERAL SPEC. TO REFER : USB SERIES SPEC.
4. FOR WAVE SOLDERING LEAD-FREE PROCESS
5. PART NO. : 1423A4-0120- X X R
 - X: ROHS
 - X: MATERIAL:
 - X: HOUSING: PBT,COLOR: BLACK
 - R: PLATING:
 - 3. CONTACT: Ni 50u",Au 5u",Tin 100u";
 - SHELL: Ni 50u";

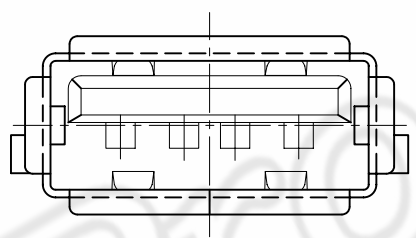

COPLIANCE WITH THE REQUIEMENT RoHS HF SONY00259 OTHER
 ※ NO USING RESTRICTED AND BANNED SUBSTANCE

CUSTOMER DRAWING				LITE Liteconn Co.,Ltd.			
-TOLERANCES- UNLESS OTHERWISE SPECIFIED						TITLE: USB A 母座 4PIN 180度 DIP	
X.X	±0.35	X.X*	±3*	APPD:	DWG NO: 1423A4-0120-32R		
X.XX	±0.25	X.XX*	±2*	CHECK:	DATE	SCALE	UNIT
X.XXX	±0.15	X.XXX*	±1*	DRAW: ZHULIZHI	2011.01.14	1:1	MM
							PAGE 1/1